



F Series Concrete Pulverizer











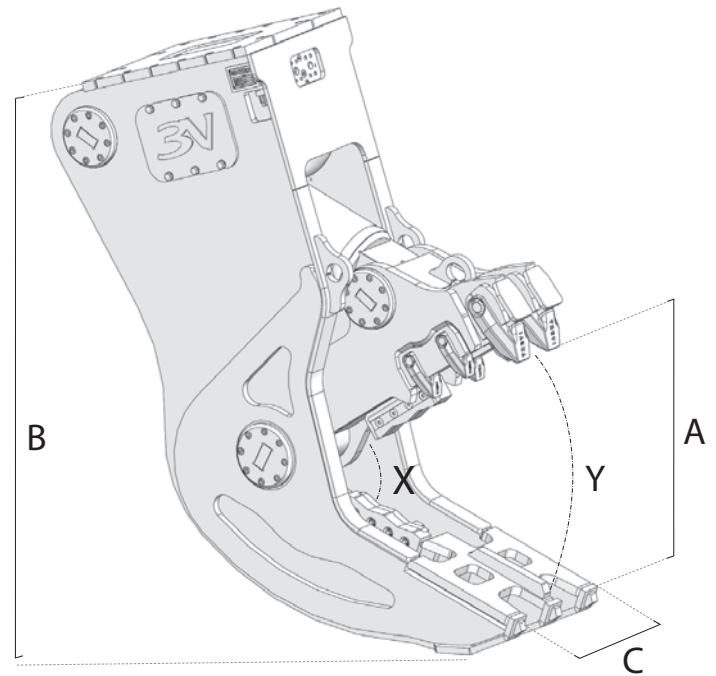



UK Dealer Sales & Service

Northerntrack Ltd
Climax Works
Garnet Road
Leeds LS11 5JD

Tel. +44 (0)113 2762 300
Fax +44 (0)113 2762 400
www.northerntrack.co.uk
info@northerntrack.co.uk

F Series



		F 07	F 12RD*	F 18RD*	F 20RRD*	F 25RD*	F 30RD*	F 70RD*
 (1)	t.	6 : 10	13 : 17	18 : 25	23 : 28	25 : 32	33 : 45	65 : 85
	kg.	550	1190	1910	2310	2490	3070	6430
A	mm.	475	690	810	810	870	950	1250
B	mm.	1330	1740	1850	2230	1955	2100	2670
C	mm.	330	420	470	470	570	650	800
	mm.	140	220	260	260	260	260	325
X	t.	70	150	200	200	235	275	415
Y	t.	25	65	80	80	95	105	170
Ø max	mm.	20	30	40	40	40	50	75
 	bar	250	310	310	310	310	310	340
 	l/min.	40 / 60	120 / 200	200 / 300	200 / 300	250 / 350	300 / 400	450 / 600
  max	bar	/	/	/	140	/	/	/
  max	l/min.	/	/	/	10	/	/	/

(*) Modello disponibile con denti intercambiabili imbullonati / (1) Accoppiamento escavatore-attrezzatura consigliato

(*) Bolted interchangeable teeth version available / (1) Excavator-equipment recommended combination

(*) Modèle disponible avec dents boulonnées interchangeables / (1) Couplage pelle-équipement recommandé

(*) Modelo equipado con dientes intercambiables atornillados / (1) Combinación excavadora-implemento aconsejado

(*) Model mit verschraubten Wechselzähnen / (1) Empfohlene Kombination von Bagger und Ausrüstung