



## BVR Series Screening Bucket



UK Dealer Sales & Service

Northerntrack Ltd  
Climax Works  
Garnet Road  
Leeds LS11 5JD

Tel. +44 (0)113 2762 300  
Fax +44 (0)113 2762 400  
[www.northerntrack.co.uk](http://www.northerntrack.co.uk)  
[info@northerntrack.co.uk](mailto:info@northerntrack.co.uk)

# BVR Series

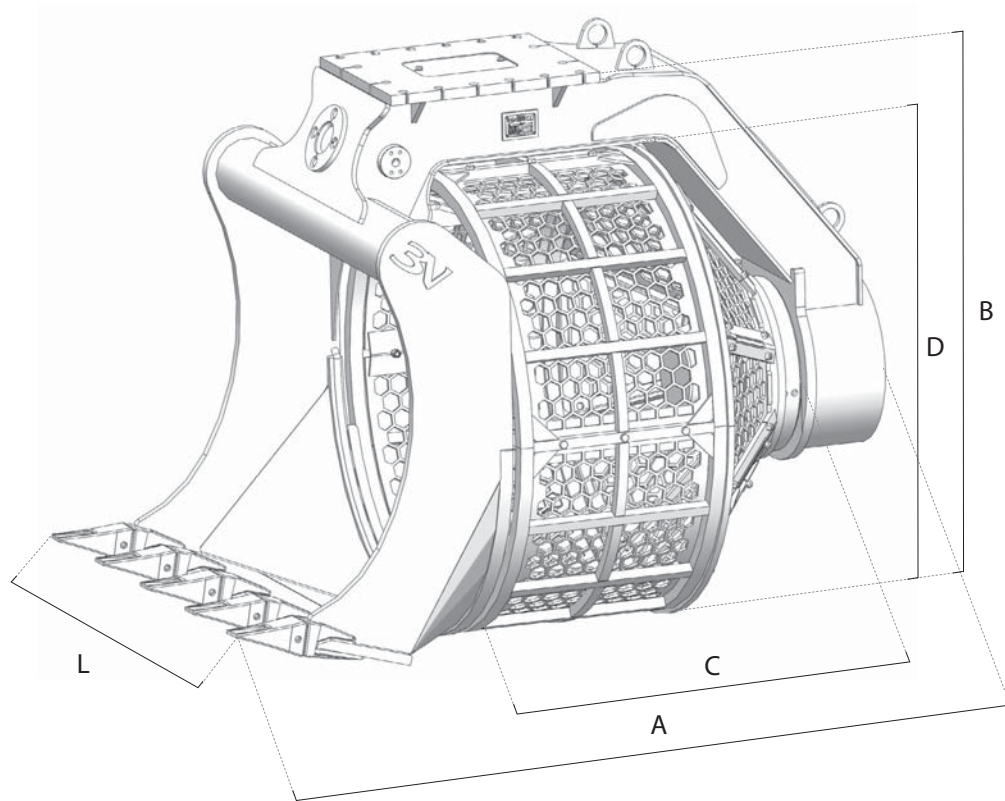

**HARDOX®**  
WEAR PLATE



		BVR 07	BVR 08	BVR 09	BVR 12e	BVR 14e	BVR 15e	BVR 19e
(1)	t.	3 : 5	5 : 8	8 : 12	13 : 16	17 : 21	22 : 30	31 : 40
	kg.	250	350	690	1320	1570	1810	2550
A	mm.	1070	1175	1480	1950	2190	2250	2600
B	mm.	805	930	1055	1460	1650	1890	2000
C	mm.	445	515	690	790	925	980	1040
D	mm.	640	750	840	1170	1340	1560	1700
L	mm.	700	800	900	1200	1400	1600	1750
Cap. SAE	m <sup>3</sup>	0,2	0,3	0,4	0,75	0,9	1,1	1,5
	bar	100 / 120	100 / 120	100 / 120	200 / 220	200 / 220	200 / 220	200 / 220
	l/min.	30 / 50	30 / 50	50 / 70	40 / 80	40 / 80	40 / 80	40 / 80
	rpm	18 / 24	18 / 24	18 / 24	18 / 35	18 / 35	18 / 35	18 / 35

(1) Accoppiamento escavatore-attrezzatura consigliato (1) Excavator-equipment recommended combination (1) Couplage pelle-équipement recommandé (1) Acoplamiento excavadora-implemento aconsejado (1) Empfohlene Kombination von Bagger und Ausrüstung